

PINES OF WESTLAKE - PHASE II

A SUBDIVISION IN SECTION 5, TOWNSHIP 43 SOUTH, RANGE 41 EAST, CITY OF WESTLAKE,
PALM BEACH COUNTY, FLORIDA, BEING A REPLAT OF TRACT "V", PINES OF WESTLAKE - PHASE I,
PLAT BOOK 136, PAGES 3 THROUGH 21, INCLUSIVE, PUBLIC RECORDS OF PALM BEACH COUNTY, FLORIDA.

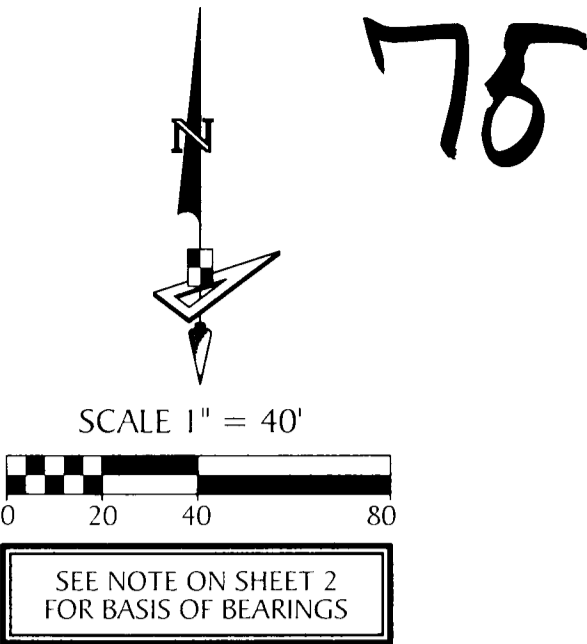

75

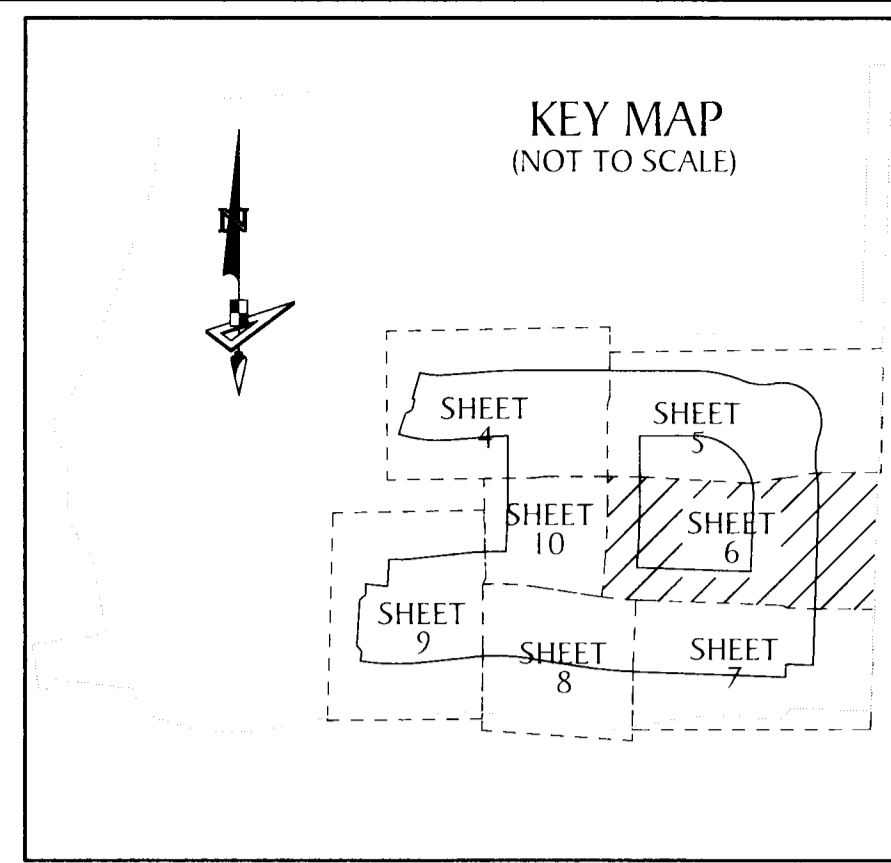
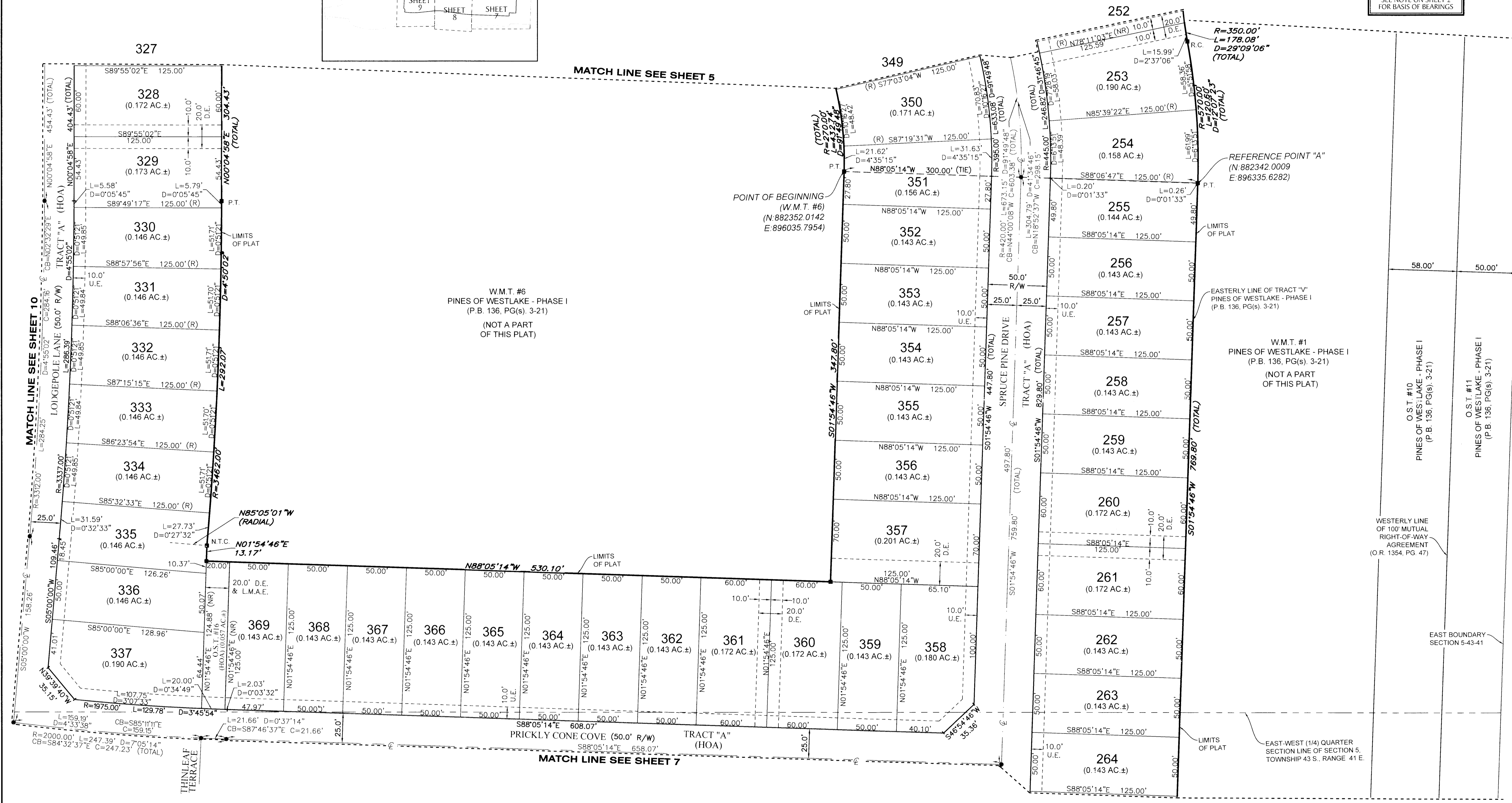

W.M.T. #6
PINES OF WESTLAKE - PHASE I
(P.B. 136, PG(s) 3-21)
(NOT A PART
OF THIS PLAT)

W.M.T. #1
PINES OF WESTLAKE - PHASE I
(P.B. 136, PG(s) 3-21)
(NOT A PART
OF THIS PLAT)

O.S.T. #10
PINES OF WESTLAKE - PHASE I
(P.B. 136, PG(s) 3-21)

O.S.T. #11
PINES OF WESTLAKE - PHASE I
(P.B. 136, PG(s) 3-21)

LEGEND

- | | | | |
|---|---|---------------------------------------|--|
| P.O.B. ----- POINT OF BEGINNING | O.S.T. ----- OPEN SPACE TRACT | D ----- DELTA ANGLE | R.C. ----- REVERSE CURVATURE |
| P.O.C. ----- POINT OF COMMENCEMENT | P.B.C. ----- PALM BEACH COUNTY | CB ----- CHORD BEARING | R.I. ----- RADIAL INTERSECTION |
| P.B. ----- PLAT BOOK | U.E. ----- UTILITY EASEMENT | C ----- CHORD | R/W ----- RIGHT-OF-WAY |
| D.B. ----- DEED BOOK | D.E. ----- DRAINAGE EASEMENT | N.T.I. ----- NON-TANGENT INTERSECTION | (NR) ----- RADIAL |
| O.R./O.R.B. ----- OFFICIAL RECORDS BOOK | L.M.A.E. ----- LAKE MAINTENANCE ACCESS EASEMENT | N.T.C. ----- NON-TANGENT CURVATURE | (NR) ----- NON-RADIAL |
| PG./PG(S) ----- PAGE(S) | 5-43-41 ----- SECTION-TOWNSHIP-RANGE | P.C. ----- POINT OF CURVATURE | HOA ----- HOMEOWNERS ASSOCIATION |
| NAD ----- NORTH AMERICAN DATUM | R ----- RADIUS | P.T. ----- POINT OF TANGENCY | S.I.D. ----- SEMINOLE IMPROVEMENT DISTRICT |
| W.M.T. ----- WATER MANAGEMENT TRACT | L ----- ARC LENGTH | C.C. ----- COMPOUND CURVATURE | |

GeoPoint
Surveying, Inc.

4152 W. Blue Heron Blvd.
Suite 105
Riviera Beach, FL 33404

Phone: (561) 444-2720
www.geopoint-survey.com
Licensed Business Number LB 7768

SHEET 6 OF 10 SHEETS